

Numerical Control

CybTouch 8 PS

The CybTouch 8 PS is available as a box or panel version, controlling 3 or 4 axes.

Its revolutionary fully touch screen interface makes it as easy to use as a positioner control.

The optional graphical profile drawing and manual sequencing features make the CybTouch 8 PS a powerful, efficient and productive numerical control for your synchronized press-brake.

The new beam management offers smoother and faster movements with higher precision.

CybTouch 8 PS provides a high speed radio RFLink wireless communication with portable PC for backup, restore, data transfer functions, including one oscilloscope for tracing the beam movements.



Ordering information

CybTouch 8 PS 3 axes (Y1-Y2-X)

In box version, white color

In box version, grey color

In panel version

NB, The emergency button is included in the delivery of the CybTouch.

The 2 other buttons on the left are not delivered and the holes are hidden.

S-CBT-83PSA12/BW

S-CBT-83PSA12/BG

S-CBT-83PSA12/P

Options:

Graphic 2D

Profile drawing with manual bend sequencing (CybTouch 8 only)

S-OFT-CBT/2D

4th axis

Upgrades the CybTouch 8 with a 4th analog axis for R axis

S-OFT-CBT/4A

RFLink USB key for PC including CybTouchTools software

S-OPT-RFLINK

Wireless
RFLink USB
key for PC.



Advantages

FOR OEM

- Complete set of Wizards for backgauge axes and beam. Machine startup is made very simple and straightforward. Time of setup is significantly reduced and more reliable.
- RFlink wireless radio frequency data communication allows easy and fast backup / restoring of parameters, parts and tools. During startup, the positioning beam curves can immediately be observed and controlled on the PC. All this without any cable connection to the numerical control *.
- Reduced electrical wiring, electrical cabinet size and equipment for lower set-up costs on each press brake.
- Flexible software for axes configuration, inputs-outputs and auxiliary functions according to specific needs.
- Screen content can be simplified to its essential minimum by removing all unused functions, buttons or information.
- New indexing functions reduce the quantity of switches and wiring, while providing more reliable indexing.
- CybTouch 8 PS accepts encoders with or without complementary signals.
- Available as integrated into a box to be mounted on an arm or in panel version.
- Can easily be integrated into existing electrical box diagrams. Ideal for upgrading machines without NC with minimal changes.
- RFlink*, a wireless radio frequency transmission integrated in the CybTouch, allows easy parameters backups or firmware upgrades. This provides modern, fast and simple communication, with no need to open the housing, no need of connecting cable.

FOR END USER

- Very intuitive, no explanations required.
- Operator immediately feels confident and comfortable using this control. User intuitively enters the angle, the desired position of the bend and the thickness of the material. No need to erase, memorize or change modes. The depth and back gauges, pressure and crowning are automatically adjusted.
- EasyBend page provides immediate easy use of the machine: a second operator can briefly interrupt production without changing the program when an urgent bend is required.
- Profile drawing and manual sequencing (option) for fast and precise program creation, as well as manual bend sequencing.
- Energy saving thanks to integrated Eco mode function that automatically stops the main pump after a chosen time of inactivity.
- Fully touch screen human machine interface offers the best of modern technology.
- Colors are vivid but not aggressive, providing excellent readability thanks to the large characters and big buttons.
- Recurrent programs for producing complex parts can be created and memorized for easy re-use.
- Pop-up messages for security or external malfunctions.
- RFlink wireless radio frequency data communication allows backup and restoring operations without any cable connection to the numerical control *.
- Many languages available directly in the CybTouch 8 PS.
- Internal backup in a special safe memory allows the user to restore at any time the original parameters; machine is running again in an extremely short time in the event of a memory loss or involuntary parameter modification.
- The USB port allows easy backup and parts transfers.

**Need RFlink USB key (option)*

Axis and bending functions

The below elements are available and can be configured on CybTouch 8 PS by the OEM. However, some functions depend on the machine construction.

 Available features depend on the number of available axes and inputs/outputs.

Back gauge axis & bending beam

Wizards and auto-tuning of the axes (including for the bending beam).
Oscilloscope for the beam trajectories via RFlink (without cable).
Indexing in several modes (including for the bending beam).
Encoders with or without complementary signals.
Inch / mm.

Bending features

Program page at start up for quick accessibility.
User friendly tool management.
Automatic calculation of: <ul style="list-style-type: none"> • Bend depth. • Bend pressure. • Back gauge positioning. • Crowning: <ul style="list-style-type: none"> ▪ Standard calculation. ▪ Automatically calculated if 3 resulting angles are measured. • Angle correction. • Bend allowance. • Manual bend sequencing. (according to the programmed material, thickness, bend angle and selected tools).
Pressure management.
Crowning (pressure or mechanical type).
Up to 10 pre-programmable types of materials.
Backgauge clearance during the bending process (yes / no).
Automatic back gauge correction according to the bend and flange length.
Sequence repetition.
Part counter with auto-stop.
Time and stroke counters for oil service.
Eco mode.
Pump start button.

Memory capacity

Punches	100
Dies	100
Programs	300
Sequences per program	24

Technical Characteristics

	CybTouch 8 PS
<i>Screen</i>	7" color graphic CRT screen, 800 x 480 pixels with LED backlight control.
<i>Work memory</i>	SRAM /SDRAM
<i>System memory</i>	FLASH memory with firmware update via RFlink.
<i>Communication</i>	Cybelec RFlink (radio frequency link). micro USB port (for memory stick only)
<i>X – R Axes</i>	<ul style="list-style-type: none"> • +/- 10VDC management of AC/DC drives and motors. • 0-10 VDC frequency converter for AC asynchronous motors. • SP-SN-HS 2 speeds mode. • SP-SN 0-10 VDC 2 adjustable speeds.
<i>Units</i>	inch/mm conversion.
<i>Power supplies</i>	<ul style="list-style-type: none"> • numerical control: stabilized + 24VDC -15% / + 20% 15W • digital inputs/outputs: stabilized + 24VDC -15% / + 20%
<i>Encoder inputs</i>	3 (+ 1) encoders 5 VDC or 12 VDC* or 24 VDC* (* = external power supply). complementary signals are not necessary, but recommended.
<i>Power supplies for encoders</i>	5 VDC (supplied by CybTouch) max. 250 mA for each encoder.
<i>Digital inputs</i>	8 inputs. optocoupled.
<i>Analog inputs</i>	2 analog inputs 0-10 VDC. short circuit proof.
<i>Digital outputs</i>	12 outputs optocoupled and short circuit proof. 24 VDC source mode, max. 0.5 A. possibility to define 2 outputs for doubling the current.
<i>Analog outputs</i>	6 analog outputs +/-10 VDC, Y1-Y2-X-R, pressure and crowning. impedance out < 100 Ω, short circuit proof. load ≥ 2 kΩ (max 15 mA).
<i>Reference voltage</i>	10VDC reference. impedance out < 100 Ω, short circuit proof. load ≥ 2 kΩ (max 15 mA).
<i>Operating conditions</i>	min. 5° Celsius, max. 40° Celsius. relative humidity 10 to 85% noncondensing.
<i>Dimensions</i>	See diagram below.
<i>EC Directives</i>	IEC61131-2.

Dimensions

Box version

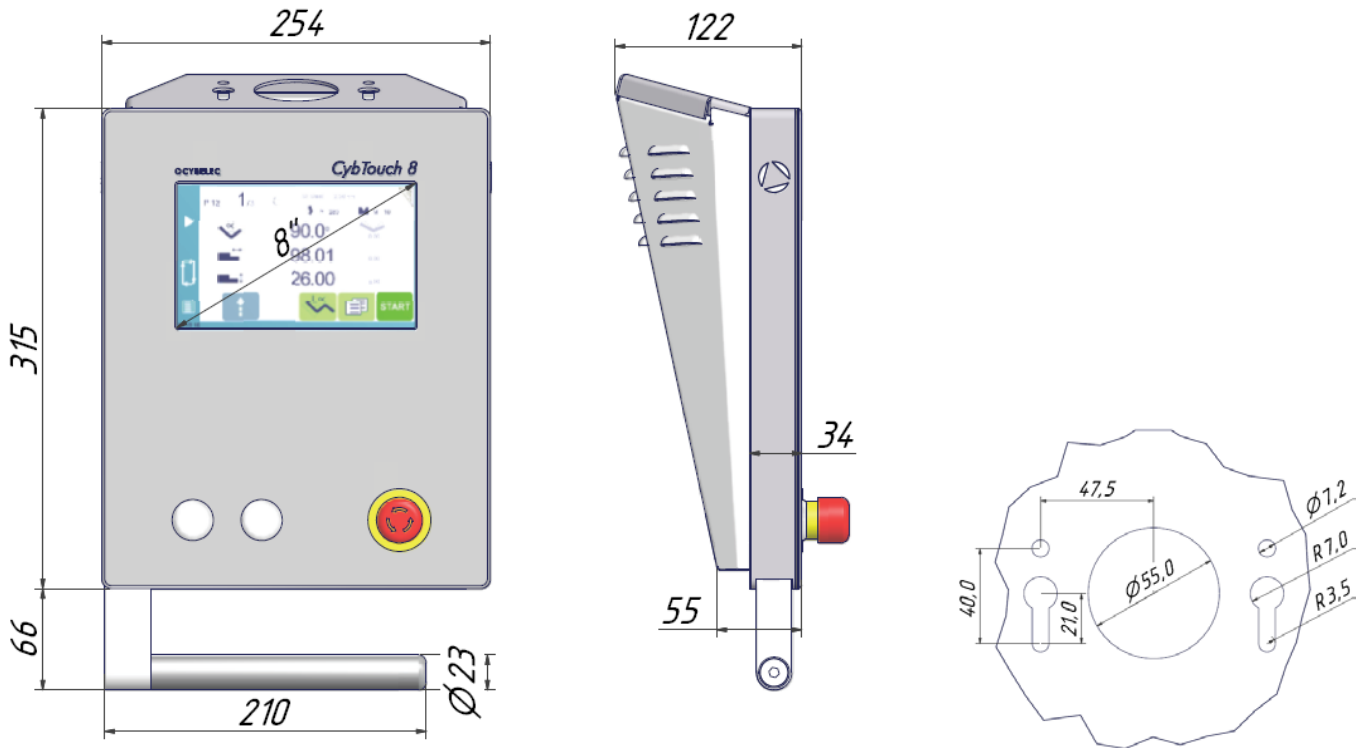

Panel version

